

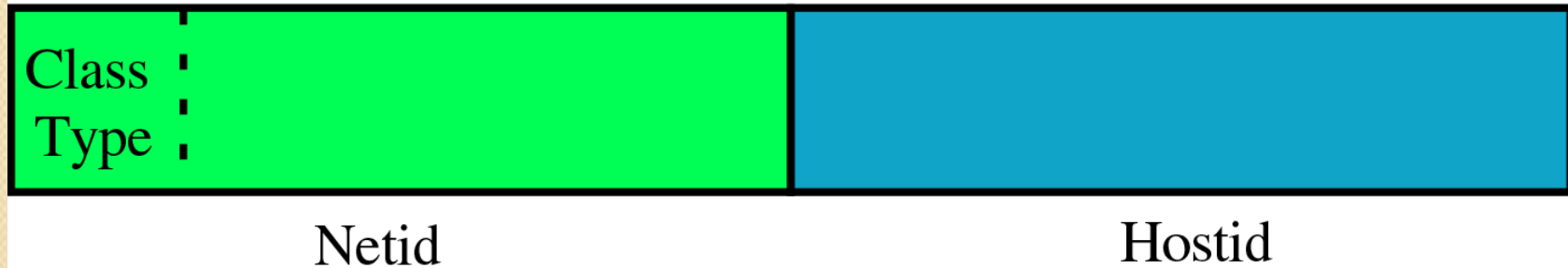

# IP v4 Addressing

# Introduction

An Internet address is made of four bytes (32 bits) that define a host's connection to a network.



Note

***An IP address is a  
32-bit  
address.***

Note

***The IP addresses  
are  
unique.***

## ***RULE:***

**If a protocol uses  $N$  bits to define an address, the address space is  $2^N$  because each bit can have two different values (0 and 1) and  $N$  bits can have  $2^N$  values.**

## Note

***The address space of IPv4 is***

***$2^{32}$***

***or***

***4,294,967,296.***

An address space is the total number of addresses used by the protocol.



## *Binary Notation*

**01110101 10010101 00011101 11101010**

# Dotted-decimal notation

10000000

00001011

00000011

00011111

128.11.3.31





## *Example 1*

Change the following IP address from binary notation to dotted-decimal notation.

10000001 00001011 00001011

*Solution* 11

*129.11.11.239*

## *Example 2*

Change the following IP address from dotted-decimal notation to binary notation.

111.56.45.78

## *Solution*

01101111 00111000 00101101 01001110

### *Example 3*

Find the error, if any, in the following IP address:

111.56.045.78

### *Solution*

There are no leading zeroes in dotted-decimal notation (045).

### *Example 3 (continued)*

Find the error, if any, in the following IP address:

75.45.301.14

### *Solution*

In dotted-decimal notation, each number is less than or equal to 255; 301 is outside this range.

## *Unicast, Multicast, and Reserved Addresses*

Addresses in classes A, B, and C are for unicast communication, from one source to one destination. A host needs to have at least one **unicast address** to be able to send or receive packets.

Addresses in class D are for multicast communication, from one source to a group of destinations. If a host belongs to a group or groups, it may have one or more **multicast addresses**. A **multicast address** can be used only as a destination address, but never as a source address.

Addresses in class E are reserved. The original idea was to use them for special purposes. They have been used only in a few cases.

Every router and host on internet has a unique IP address .all IP address are of 32 bit and they use source and destination field of the IP header. The first part of address is called network ID which identify the network on the internet and second, called the host ID used to identify the individual host on that network.

### Classes of IP address :-

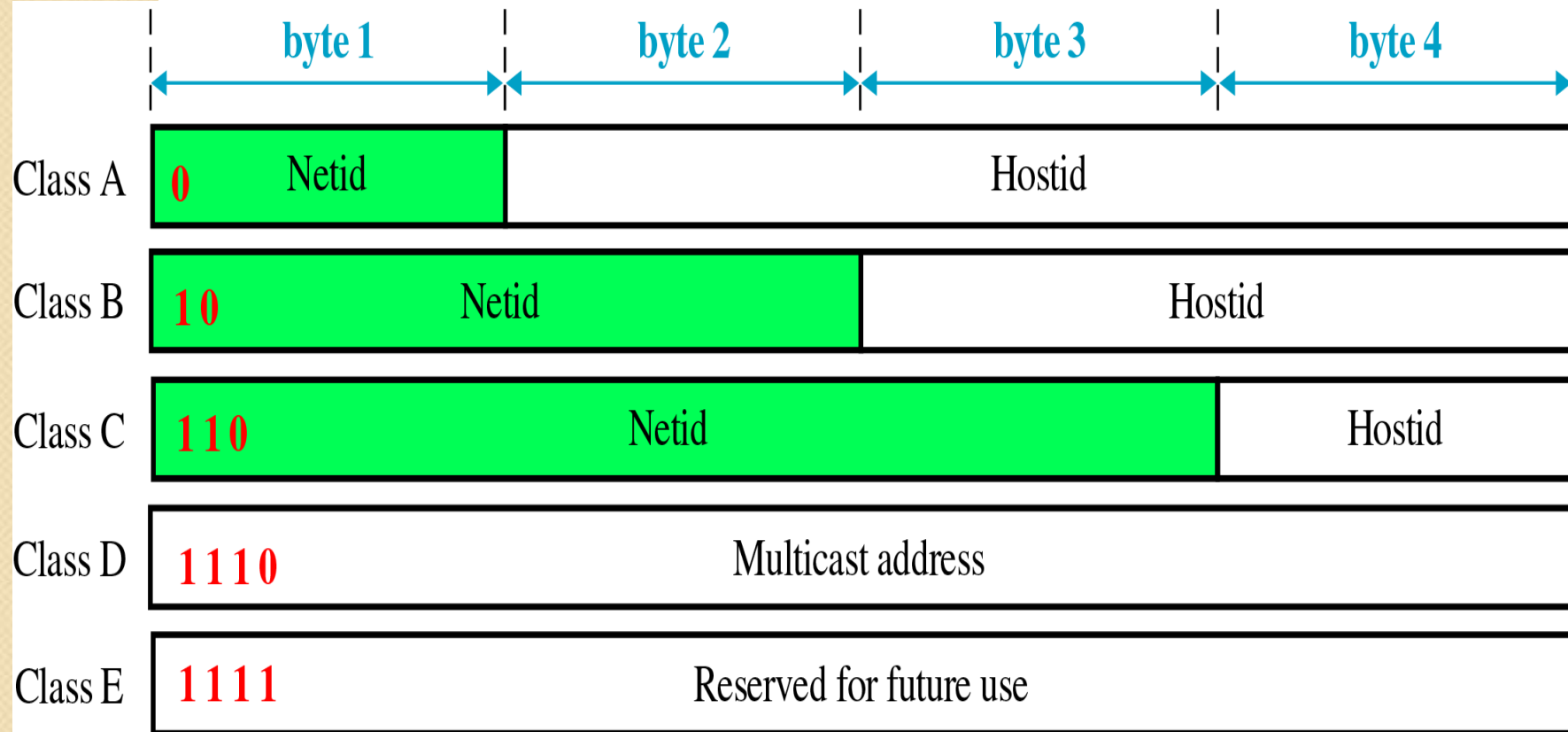

# Netid and hostid

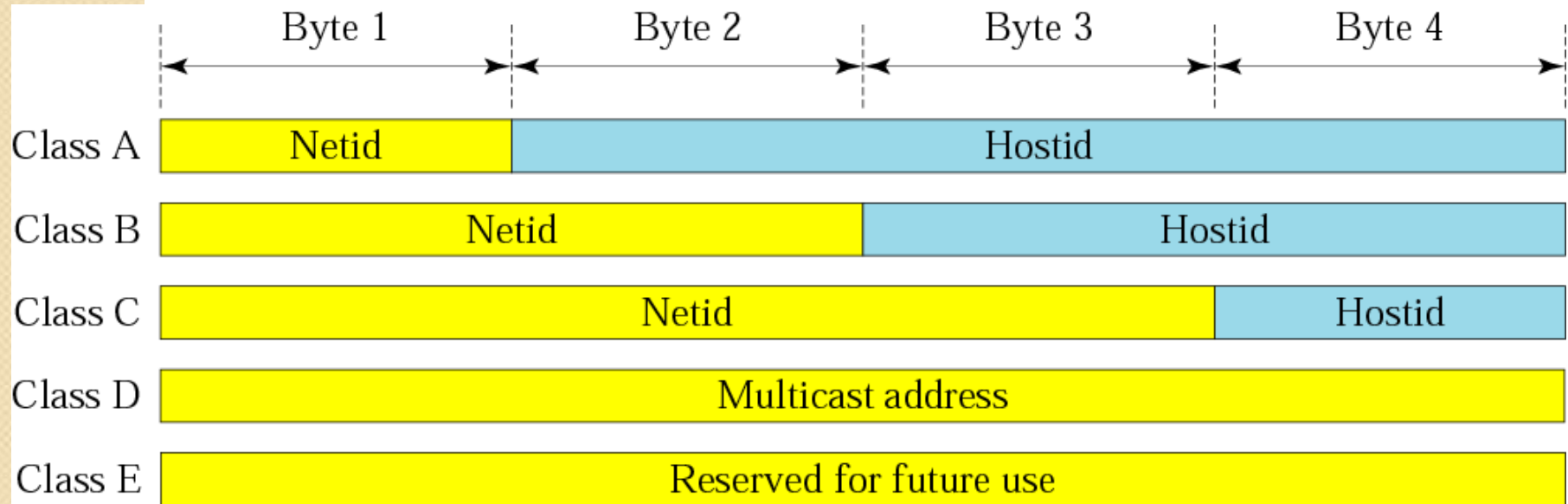







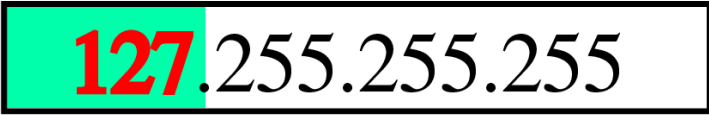

## Note

*In classful addressing,  
the address space is  
divided into five classes:  
**A, B, C, D, and E.***

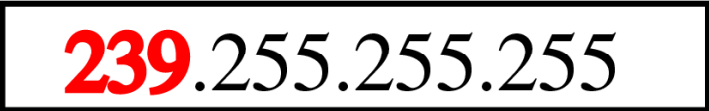

# Class Ranges of Internet Addresses

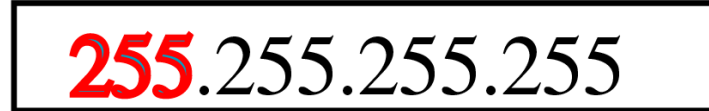
	From	To
<b>Class A</b>	 Netid    Hostid	 Netid    Hostid
<b>Class B</b>	 Netid    Hostid	 Netid    Hostid
<b>Class C</b>	 Netid    Hostid	 Netid    Hostid
<b>Class D</b>	 Group address	 Group address
<b>Class E</b>	 Undefined	 Undefined

# Class A address

32 bit



The n/w field is of 7 bit and the host field is of 24 bits . One bit is used for the class type. So the n/w field can have numbers b/w 0 to 127. but the host number ranges from 0.0.0.0 to 127.255.255.255. hence in class A there can be 127 types of n/w's. bit 0 in fist field indicates that it is class A n/w address.

$2^7 \ 2^6 \ 2^5 \ 2^4 \ 2^3 \ 2^2 \ 2^1 \ 2^0$

0 0 0 0 0 0 0 0

0 0 0 0 0 0 0 1

.

0 1 1 1 1 1 1 1

→ 0

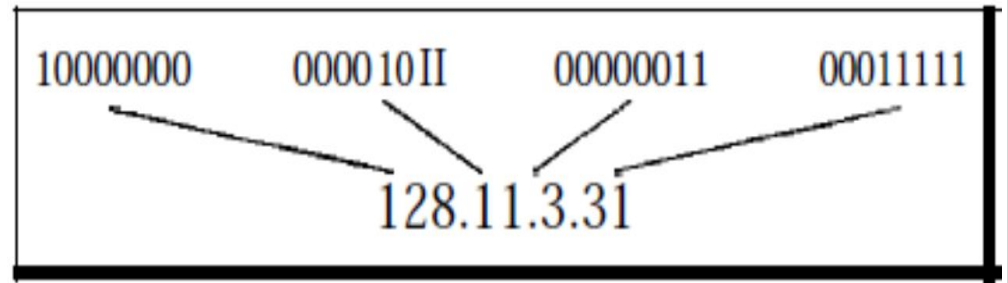

Same way total number of host will be ranges from 0. 0.0.0 to 127. 255.255.255

→ 127

# Class A address

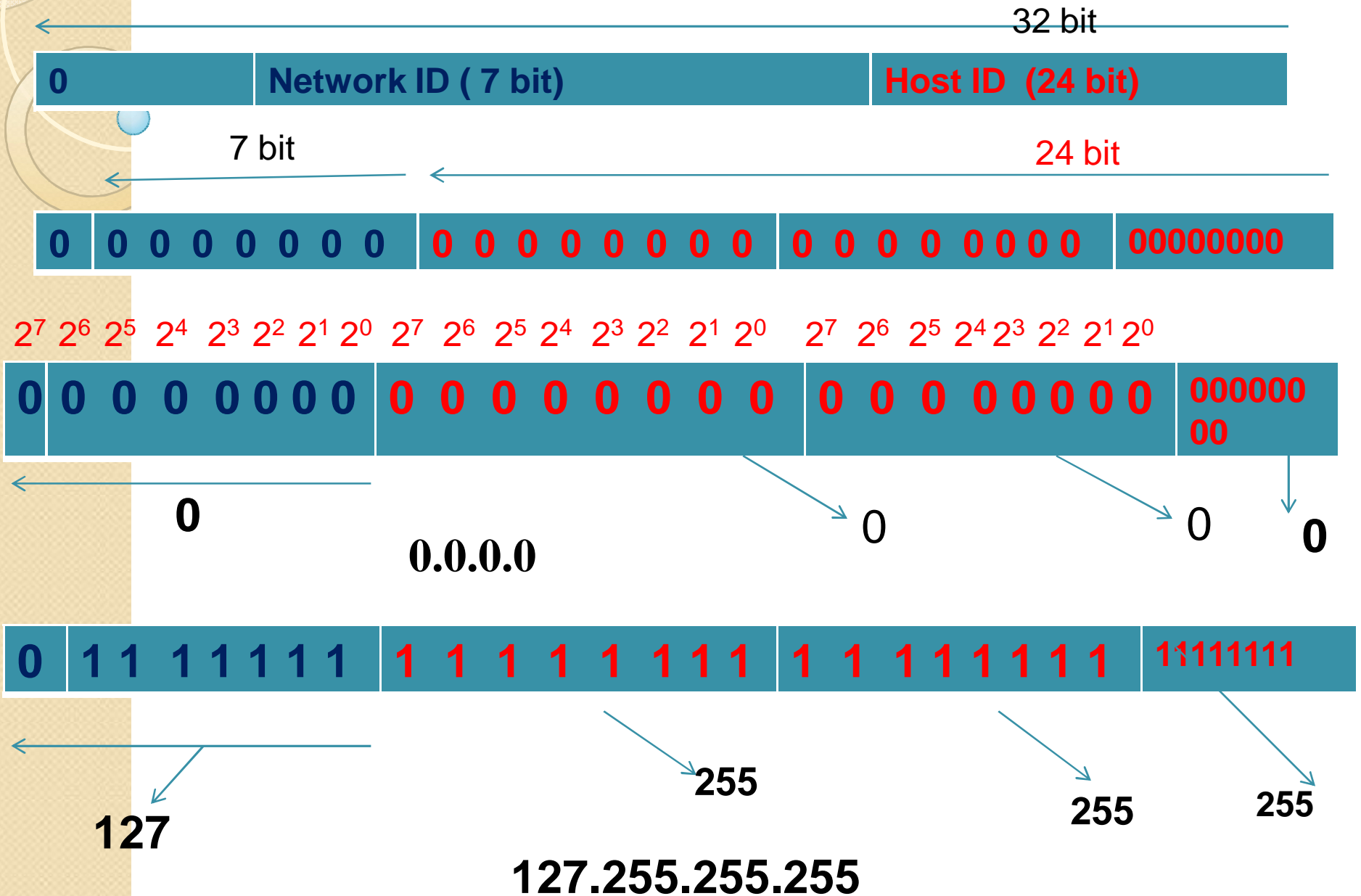

# Blocks in class A

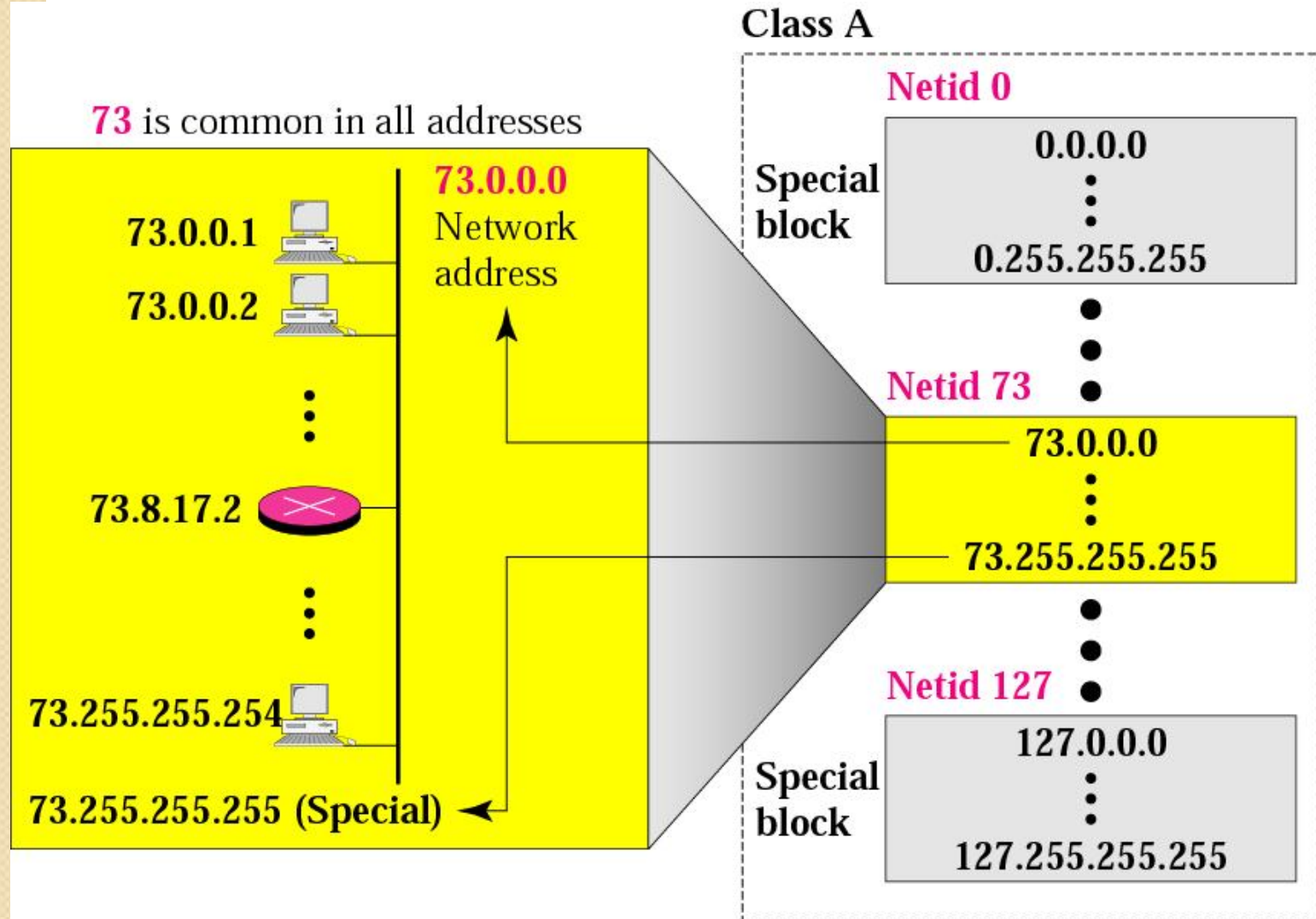

128 blocks: 16,777,216 addresses in each block

# Network Address in Class A

- Class A divided in to 128 blocks.
- We can assign class A addresses to 128 org.'s. each having 16,777,216 nodes .
- Each block have different netid. First block covers address from **0.0.0.0** to **0.255.255.255**. here netid is 0.
- 2<sup>nd</sup> block covers from **1.0.0.0** to **1.255.255.255** with netid as **1**.
- Last block covers addresses from **127.0.0.0** to **127.255.255.255** with netid as 127.
- **The first address of each block is used as network address** which assigned to any organization and identify the organization to the rest of network.
- **A network address is an address that defines a network. It can not assigned to a host. A n/w address is netid+hostid .**

Note

***Millions of class A addresses  
are wasted.***

# Class B address

32 bit



The first field defines the class type and second field defines the networks. And last field defines the hosts. The n/w field values lies b/w 128 to 191. The first block covers the address from 128.0.0.0 to 128.255.255.255 and last block covers from 191.0.0.0 to 191.255.255.255.

14 bits (6 + 8)



Range from 0 to 255

Range from 0 to 255

Range from 0 to 255

Ranges from 128 to 191

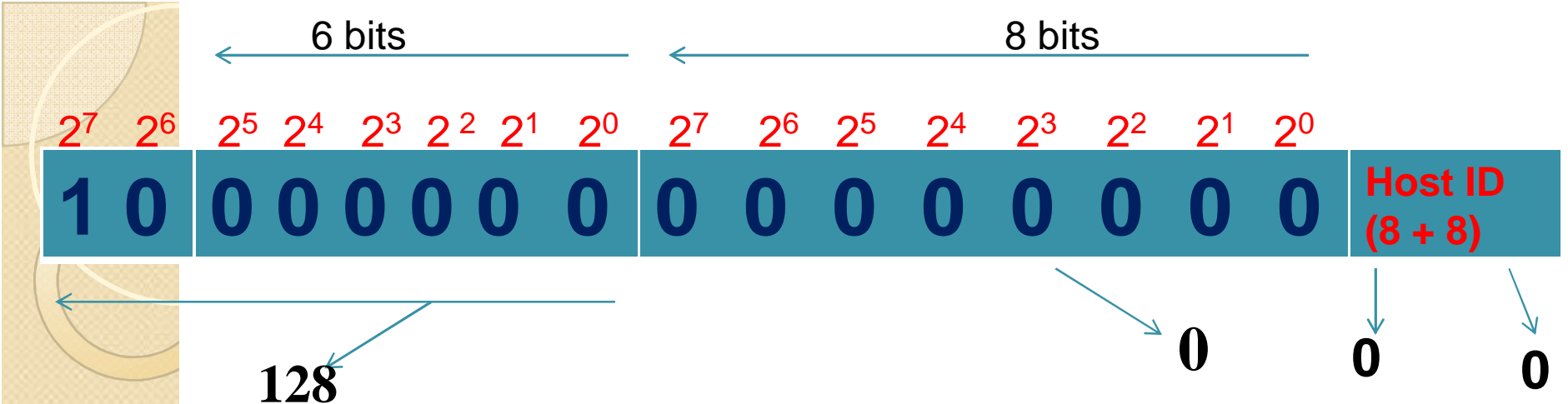

**128.0.0.0**



**191.255.255.255**



# Blocks in class B

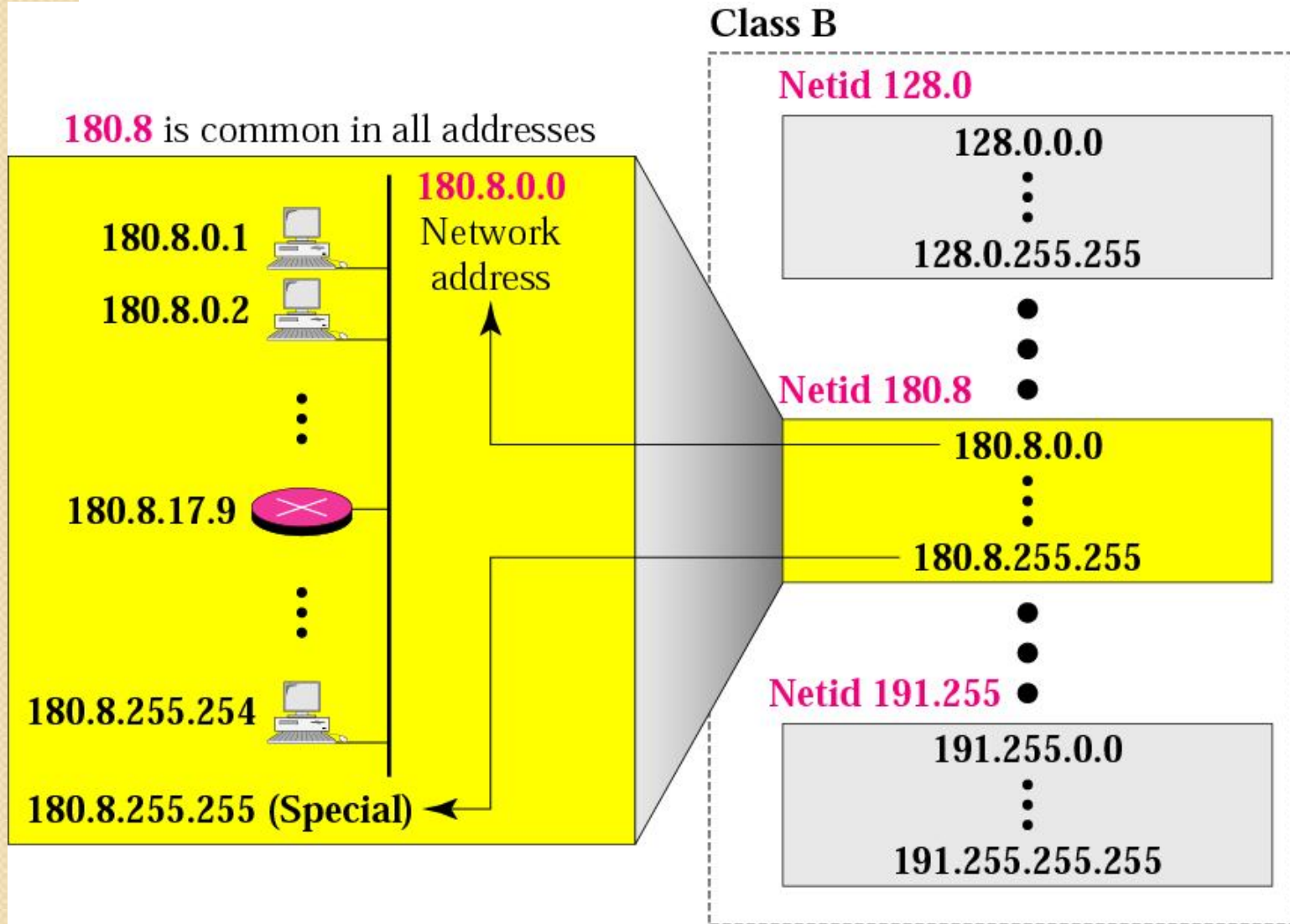

16,384 blocks: 65,536 addresses in each block

# Class B Addresses

- Class B divided in to 16384 blocks.
- We can assign B class addresses to 16384 org.'s, each having 65536 nodes.
- Each block has different netid. First block covers address from **128.0.0.0** to **128.0.255.255**. Here netid is **128.0**.
- 2<sup>nd</sup> block covers from **128.1.0.0** to **128.1.255.255** with netid as **128.1**.
- Last block covers addresses from **191.255.0.0** to **191.255.255.255** with netid as **191.255**.
- **Class B address are assigned to middle size org. having a large no's of nodes .**

Note

***Many class B addresses  
are wasted.***

# Class C address

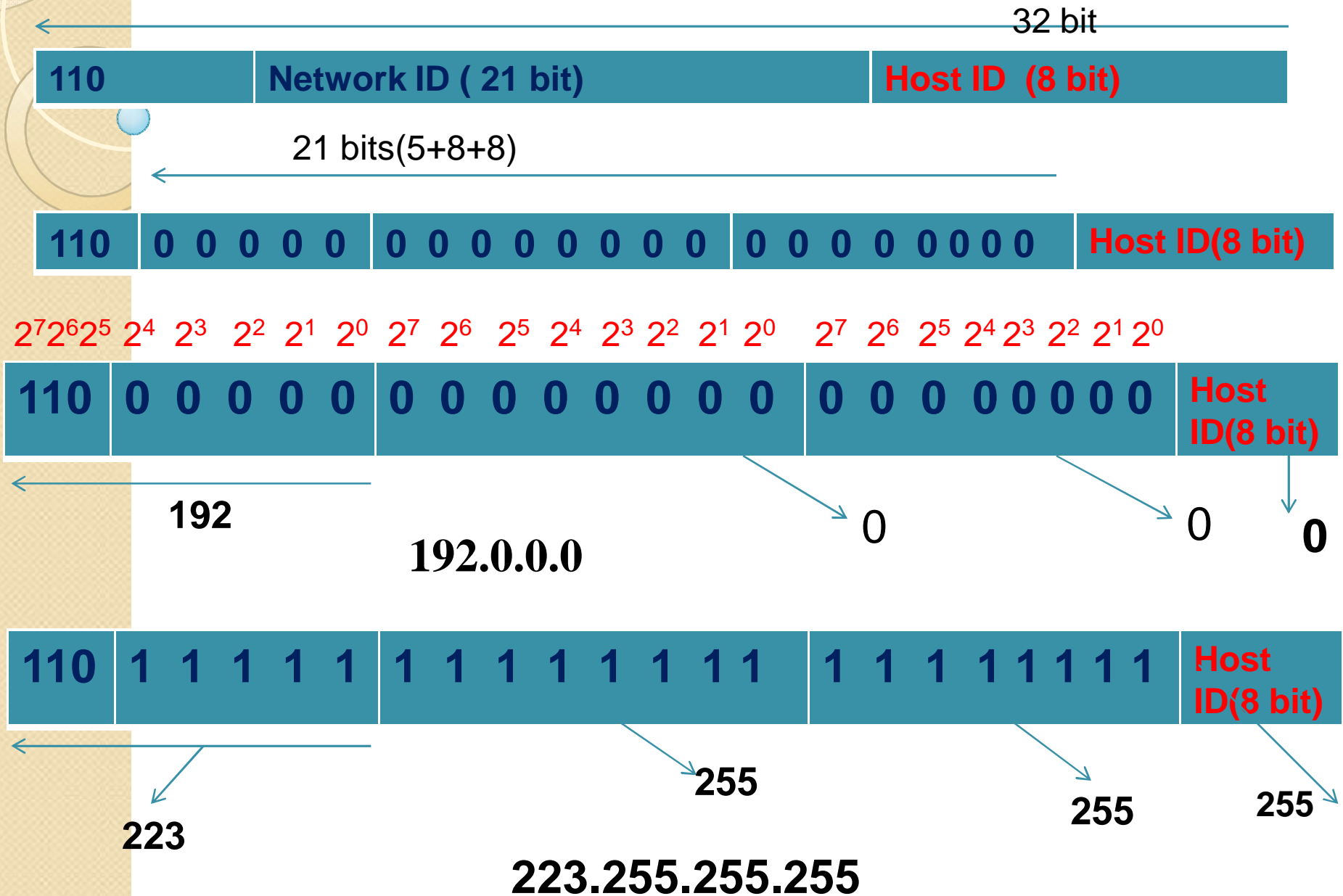

# Blocks in class C

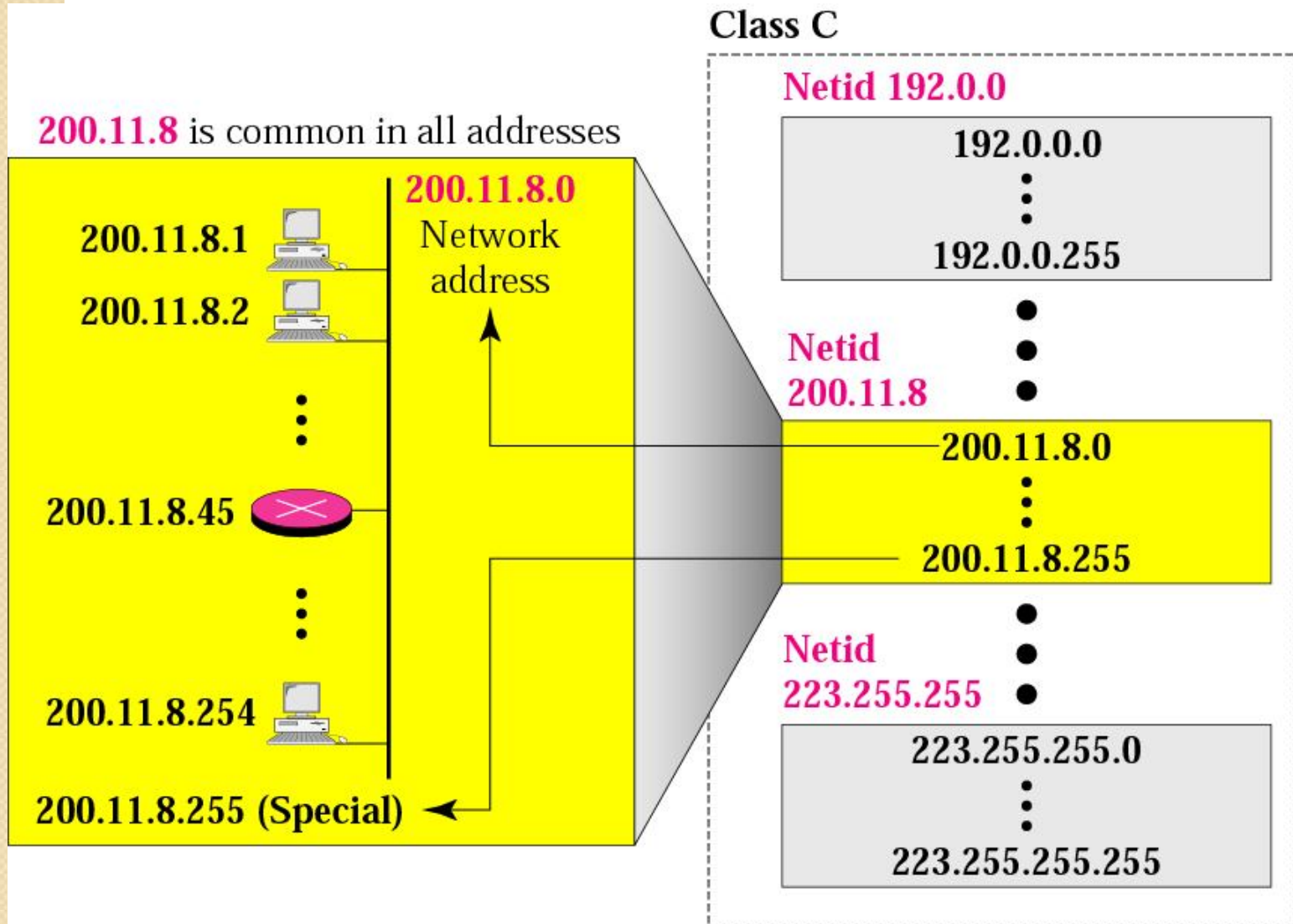

2,097,152 blocks: 256 addresses in each block

# Class C Addresses

- Class C divided in to 2,097,152 blocks.
- We can assign C class addresses to 2,097,152 org.'s. each having 256 nodes.
- First block covers address from **192.0.0.0** to **192.0.0.255**. here netid is **192.0.0**
- Last block covers addresses from **223.255.255.0** to **223.255.255.255** with netid as **223.255.255**.
- Class C address are assigned to small size org. having a less no's of nodes .

Note

***The number of addresses in a class C block is smaller than the needs of most organizations.***



**To be continued**